

# Tankless Water Heater Accessories

## Specification Sheet

### ScaleShield

- Provides superior limescale prevention and corrosion control within the water heater and plumbing system
- Contains water conditioning cartridge that creates scale-inhibiting solution for use with all tankless water heater models
- Comes included with 1 ScaleShield cartridge, housing, transparent o-ring, and housing wrench tool is also included for servicing the accessory

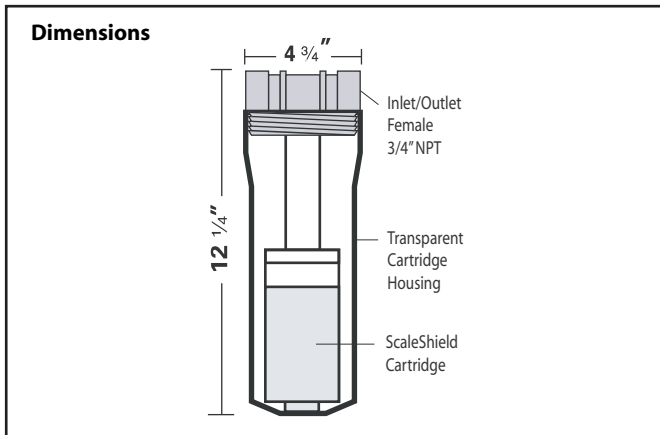

- ScaleShield**
- ScaleShield - Small (#SS-HB-1)
  - Cartridge - Small (#HBC-1)
  - ScaleShield - Large (#SS-HB-2)
  - Cartridge - Large (#HBC-2)

**Compatible with All Models**

NR66 Series	NRC111 Series
NR71 Series	NR111 Series
NR98 Series	NC250 Series
NC199 Series	NC380 Series
NCC199 Series	

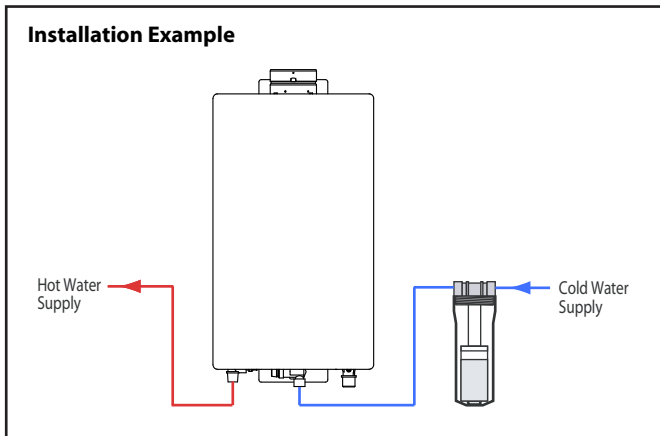

**Specifications**

Models	SS-HB-1	SS-HB-2
Max. Pressure	150psi	150psi
Max. Temperature	125 F	125 F
Connection Size	3/4" Female NPT	3/4" Female NPT
Accessories	3 Way Bypass Valve	3 Way Bypass Valve
Cartridge	HBC-1	HBC-2

**Selection Guide**

Unit	Model	Description
531/NR66 Series	SS-HB-1	Installation on cold-water line feeding tankless heater only
631/NR71 Series		
751/NR98/NC199 Series		
841/NCC199 Series	SS-HB-2	Installation on cold-water line feeding tankless heater only
842/NRC111 Series		
931/NR111/NC250 Series		
N-1321M-ASME		2 units required for installation on cold-water line feeding tankless heater only.
NC380-SV-ASME		
Whole House		Contact Noritz
Commercial		

\* Refer to the above selection guide to ensure the correct application of ScaleShield unit(s)  
 \*\* The overall level of protection will depend on the quality and chemistry of the cold supply water. Replace the cartridge when it is dissolved near the bottom of the housing.