

## Residential Ultra Low NOx Gas Water Heater



Photo is of  
URG250T6N

### The FVIR Eco-Defender Safety System<sup>®</sup> Models Feature:

- **Bradford White ICON System**<sup>™</sup>—Intelligent gas control with proven millivolt powered technology and built-in piezo igniter. A standard, off the shelf thermopile converts heat energy from the pilot flame into electrical energy to operate the gas valve and microprocessor. No need for external electricity.
  - **Enhanced Performance**—Proprietary algorithms provide enhanced First Hour Rating and tighter temperature differential.
  - **Advanced Temperature Control System**—Microprocessor constantly monitors and controls burner operation to maintain consistent and accurate water temperature levels.
  - **Intelligent Diagnostics**—An exclusive green LED light prompts the installer during start-up and provides ten different diagnostic codes to assist in troubleshooting.
  - **Pilot On Indication**—Flashing green LED provides positive indication that pilot is on.
  - **Separate Immersed Thermowell**—High-strength advanced polymer composite thermowell provides isolation between electric temperature sensor and surrounding water. No need to drain the tank when removing gas valve.
- **Defender Combustion Chamber**—Incorporates the Advanced ScreenLok<sup>®</sup> Technology Flame Arrestor and large split-door design to prevent ignition of flammable vapors outside the water heater.
- **Ultra Low NOx Burner with Primary and Secondary Air Distribution Devices**—Ensures proper air to gas ratio for reduction of NOx generated by the combustion process.
- **Digital Thermal Sensor and Resettable Thermal Switch**—Coordinates with self diagnostic control to prevent water heater operation when needed.
- **Maintenance-Free**—No regular cleaning of air inlet openings or flame arrestor is required under normal conditions.
- **Sight Window**—Offers a view into the combustion chamber to observe the operation of the pilot and burner.
- **Factory-Installed Hydrojet<sup>®</sup> Total Performance System**—Sediment reducing device that also increases first hour rating of hot water while minimizing temperature build-up in tank.
- **Vitraglas<sup>®</sup> Lining**—An exclusively engineered enamel formula that provides superior tank protection from the highly corrosive effects of hot water. This formula (Vitraglas<sup>®</sup>) is fused to the steel surface by firing at a temperature of over 1600°F (871°C).
- **Insulation System**—Non-CFC foam covers the sides and top of the tank, reducing heat loss. This results in less energy consumption, improved efficiencies, and jacket rigidity.
- **Pedestal Base**—Rugged and durable base allows easy transport and positioning and corrosion-resistant contact with floor.
- **Water Connections**—3/4" (19mm) NPT factory-installed true dielectric fittings extend water heater life and simplify water line connections.
- **Factory-Installed Heat Traps**—Design incorporates a flexible disk that reduces heat loss in piping and eliminates the potential for noise generation.
- **Protective Magnesium Anode Rod**—Provides added protection against corrosion for long-term, trouble-free service.
- **3x4 "Snap Lock" Draft Diverter**—Allows either 3" (76mm) or 4" (102mm) vent connections with inputs of 40,000 BTU/Hr. or less. Over 40,000 BTU/Hr. has a 4" (102mm) "Snap Lock" Draft Diverter.
- **Flue Baffle**—Maximizes the amount of heat absorbed by the tank and reduces heat loss during standby periods.
- **Steel Tank**—Heavy gauge steel automatically formed, rolled, and welded.
- **T&P Relief Valve**—Installed.
- **Low Restrictive Brass Drain Valve**—Durable tamper proof design.
- **Design Certified by CSA International (formerly AGA/CGA).**
- **Complies with the latest Ultra Low NOx requirement (10 ng/J NOx limit).**

### FEATURING:



### 6 or 10-Year Limited Tank Warranties / 6 or 10-Year Limited Warranty on Component Parts.

For more information on warranty, please visit [www.bradfordwhite.com](http://www.bradfordwhite.com)

For products installed in USA, Canada, and Puerto Rico. Some states do not allow limitations on warranties. See complete copy of the warranty included with the heater.

MANUFACTURED UNDER ONE OR MORE OF THE FOLLOWING U.S. PATENTS: 5,682,666; 7,634,976; 5,660,165; 5,954,492; 6,056,542; 6,935,280; 5,372,185; 5,485,879; 5,574,822; 7,971,560; 7,992,526; 6,684,821; 6,442,178; 7,334,419; 7,866,168; 7,270,087; 7,007,748; 5,596,952; 6,142,216; 7,699,026; 5,341,770; 7,337,517; 7,665,211; 7,665,210; 7,063,132; 7,063,133; 7,559,293; 7,900,589; 5,943,984; 8,082,888; 5,988,117; 7,621,238; 7,650,859; 5,761,379; 7,409,925; 5,277,171; 8,146,772; 7,458,341; 2,262,174. OTHER U.S. AND FOREIGN PATENT APPLICATIONS PENDING. CURRENT CANADIAN PATENTS: 2,314,845; 2,504,824; 2,108,186; 2,143,031; 2,409,271; 2,548,958; 2,112,515; 2,476,685; 2,239,007; 2,092,105; 2,107,012. Defender Safety System<sup>®</sup>, ScreenLok<sup>®</sup>, Vitraglas<sup>®</sup> and Hydrojet<sup>®</sup> are registered trademarks of Bradford White<sup>®</sup> Corporation.

# Residential Ultra Low NOx Gas Water Heater

## Ultra Low NOx Models

NATURAL GAS

Meet or exceed ASHRAE 90.1b (current standard) C.E.C. Listed  
Recovery efficiency ranging up to 80%

Model Number	Nominal Capacity		DOE Rated Storage Volume (Gal.)	Nat. BTU/Hr. Input	First Hour Rating (Gal.)	Uniform Energy Factor	Recovery at 90°F Rise*		A Floor to Flue Conn. in.	B Jacket Dia. in.	C Vent Size in.	D Floor to T&P Conn. in.	E Floor to Gas Conn. in.	F Floor to Water Conn. in.	G Depth in.	Approx. Shipping Weight lbs.
	U.S. Gal.	Imp. Gal.					Nat. U.S. GPH	Nat. Imp. GPH								
URG130T6N•	30	25	29	27,000	46	0.54	29	24	59 <sup>1</sup> / <sub>8</sub>	16	3x4	49 <sup>3</sup> / <sub>4</sub> / 56 <sup>3</sup> / <sub>8</sub>	11 <sup>3</sup> / <sub>4</sub>	57 <sup>1</sup> / <sub>2</sub>	19 <sup>1</sup> / <sub>2</sub>	112
URG230T6N•	30	25	29	32,000	60	0.60	34	28	59 <sup>7</sup> / <sub>8</sub>	18	3x4	49 <sup>7</sup> / <sub>8</sub> / 56 <sup>3</sup> / <sub>8</sub>	11 <sup>3</sup> / <sub>4</sub>	57	21 <sup>1</sup> / <sub>2</sub>	119
URG140T6N•	40	33	38	34,000	64	0.59	37	31	60 <sup>3</sup> / <sub>4</sub>	18	3x4	51 <sup>1</sup> / <sub>2</sub> / 59 <sup>1</sup> / <sub>2</sub>	11 <sup>3</sup> / <sub>4</sub>	59 <sup>1</sup> / <sub>8</sub>	21 <sup>1</sup> / <sub>2</sub>	130
URG240T6N•	40	33	38	40,000	75	0.64	43	36	60 <sup>1</sup> / <sub>4</sub>	20	3x4	50 / 56 <sup>5</sup> / <sub>8</sub>	11 <sup>3</sup> / <sub>4</sub>	57 <sup>1</sup> / <sub>2</sub>	23 <sup>1</sup> / <sub>2</sub>	137
URG240S6N•	40	33	38	40,000	69	0.58	43	36	51 <sup>5</sup> / <sub>8</sub>	22	3x4	41 / 47 <sup>1</sup> / <sub>4</sub>	11 <sup>3</sup> / <sub>4</sub>	49 <sup>1</sup> / <sub>8</sub>	25 <sup>1</sup> / <sub>2</sub>	149
URG150T6N•	50	42	47	34,000	75	0.63	37	31	59 <sup>5</sup> / <sub>8</sub>	20	3x4	50 / 56 <sup>3</sup> / <sub>8</sub>	11 <sup>3</sup> / <sub>4</sub>	58	23 <sup>1</sup> / <sub>2</sub>	153
URG250T6N•	50	42	48	40,000	81	0.63	43	36	60 <sup>3</sup> / <sub>16</sub>	22	3x4	49 <sup>7</sup> / <sub>8</sub> / 57	11 <sup>3</sup> / <sub>4</sub>	58 <sup>3</sup> / <sub>16</sub>	25 <sup>1</sup> / <sub>2</sub>	160
URG250L6N•	48	40	47	40,000	77	0.63	43	36	51 <sup>5</sup> / <sub>8</sub>	24	3x4	40 <sup>5</sup> / <sub>8</sub>	11 <sup>3</sup> / <sub>4</sub>	49 <sup>3</sup> / <sub>8</sub>	27 <sup>1</sup> / <sub>2</sub>	174
URG250S6N•	50	42	47	50,000	75	0.63	54	45	59 <sup>1</sup> / <sub>2</sub>	22	4	49 <sup>7</sup> / <sub>8</sub> / 57	11 <sup>3</sup> / <sub>4</sub>	58 <sup>3</sup> / <sub>16</sub>	25 <sup>1</sup> / <sub>2</sub>	169

Model Number	Nominal Capacity		DOE Rated Storage Volume (Liters)	Nat. kW Input	First Hour Rating (Liters)	Uniform Energy Factor	Recovery at 50°C Rise*		A Floor to Flue Conn. mm.	B Jacket Dia. mm.	C Vent Size mm.	D Floor to T&P Conn. mm.	E Floor to Gas Conn. mm.	F Floor to Water Conn. mm.	G Depth mm.	Approx. Shipping Weight kg.
	Liters						Nat. Liters/Hour									
URG130T6N•	114		110	7.9	174	0.54	110		1502	406	76x102	1264 / 1432	330	1461	495	51
URG230T6N•	114		110	9.4	227	0.60	129		1521	457	76x102	1267 / 1432	298	1448	546	54
URG140T6N•	151		144	10.0	243	0.59	139		1543	457	76x102	1308 / 1511	330	1502	546	59
URG240T6N•	151		144	11.7	284	0.64	163		1530	508	76x102	1270 / 1438	298	1461	597	62
URG240S6N•	151		144	11.7	262	0.58	163		1311	559	76x102	1041 / 1200	298	1248	648	68
URG150T6N•	189		178	10.0	284	0.63	139		1514	508	76x102	1270 / 1432	330	1473	597	69
URG250T6N•	189		182	11.7	307	0.63	163		1529	559	76x102	1267 / 1448	298	1481	648	73
URG250L6N•	182		178	11.7	292	0.63	163		1311	610	76x102	1032	298	1254	699	79
URG250S6N•	189		178	14.7	284	0.63	204		1511	559	102	1267 / 1448	298	1478	648	77

Available in Natural Gas only.

For 10 year models, change suffix from "6" to "10".

\* Based on manufacturers rated recovery efficiency.

• Models feature optional top T&P location and must be specified when ordering.

Uniform Energy Factor and First Hour Rating is based on the latest AHRI directory listings.

(URG130T, URG140T, & URG150T available with top T&P location ONLY)

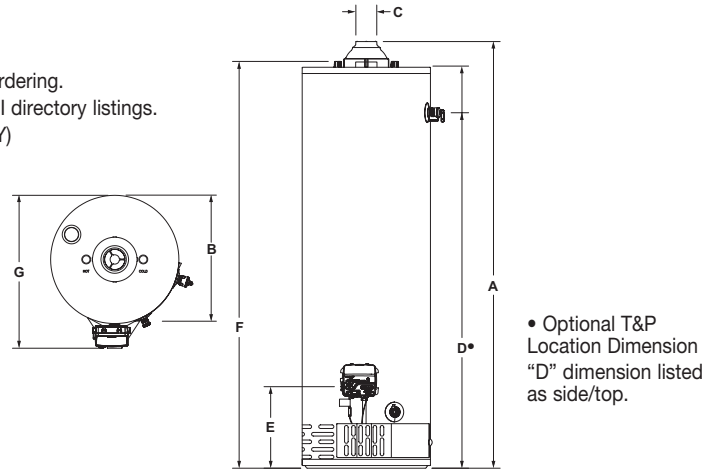

### General:

#### Meets NAECA Requirements.

All gas water heaters are certified at 300 PSI test pressure (2068 kPa) and 150 PSI working pressure (1034 kPa). All water connections are 3/4" NPT (19mm) on 8" (203mm) centers. All gas connections are 1/2" (13mm). All models design-certified by CSA International (formerly AGA/CGA), to meet ANSI standard Z21.10.1 and peak performance rated.

**Dimensions and specifications subject to change without notice in accordance with our policy of continuous product improvement.**

**Suitable for Water (Potable) Heating and Space Heating.** Toxic chemicals, such as those used for boiler treatment, shall NEVER be introduced into this system. This unit may NEVER be connected to any existing heating system or component(s) previously used with a non-potable water heating appliance.



For U.S. and Canada field service, contact your professional installer or local Bradford White sales representative.

Sales 800-523-2931 • Fax 215-641-1670 / Technical Support 800-334-3393 • Fax 269-795-1089 • Warranty 800-531-2111 • Fax 269-795-1089

International: Telephone 215-641-9400 • Telefax 215-641-9750 / [www.bradfordwhite.com](http://www.bradfordwhite.com)



Sales / Technical Support 866-690-0961 / 905-203-0600 • Fax 905-636-0666 / [www.bradfordwhite.com](http://www.bradfordwhite.com)

## Built to be the Best™

©2018, Bradford White Corporation. All rights reserved.